

Laser Safety Systems



**Your Engineered Laser
Safety Solution**

Laser Safety Systems User Manual

Revision 5 December 2023

This manual is available on-line at:

http://www.lasersafetysystems.com/files/Laser_Safety_Systems_user_manual.pdf

Table of Contents

Section		Page
1.0	Introduction	2
1.1	General Description	2
1.2	Safety Warning	2
2.0	System Installation	2
2.1	Wiring Concept	2
2.2	Start and End Nodes	3
2.3	System Power Requirements	3
2.4	Conduit and Box Selection	3
3.0	Interlock Module Descriptions	4
3.01	LSS-2380 Laser Warning Module	4
3.02	LSS-2381 Interlock Control Module	5
3.03	LSS-2382 Main Control Module	6
3.04	LSS-2383 Emergency Crash Module	8
3.05	LSS-2384 Laser / Shutter Interface Module	8
3.06	LSS-2387 Non-Defeatable Access Monitor	9
3.07	LSS-2387B Non-Defeatable Access Monitor	9
3.08	LSS-2388 Defeatable Access Control Kit	10
4.0	System Troubleshooting	10
5.0	Periodic Performance Test Procedure	13
6.0	Module Cleaning Procedure	13
7.0	Warranty	14
8.0	Return Material Authorization Procedures	14

STOP HERE: Scan this QR code with your phone and watch the video on this link, and you'll have a significant head start in understand our system wiring.



1.0 Introduction

Thank you for purchasing the Laser Interlock system. The system has been designed for long service life maintenance-free operation. All interlock functions utilize redundant trip circuitry and are designed for fail-safe fault tolerance. Please review the following chapters prior to operation of the system.

1.1 General Description

The Laser Interlock system is a collection of modules that are designed to work in a series chain. Each control module in the chain receives power from the cable and has complete knowledge of the interlock status. If a module has an interlock “crash” function, it will have the ability to secure the system regardless of its position within the chain. This method allows simple expansion of the system as the needs of the user grow.

1.2 Safety Warning

WARNING

The use of the Laser Interlock system or any other type of engineered access control does not reduce or eliminate any of the other required elements of Laser Safety (i.e. Laser Protective Eyewear) specified in ANSI Z136.1-2014, or any other applicable standard. Periodic verification of all functions of the interlock system is required to ensure proper operation. This verification should be performed every six months for most industrial settings. The verification should be performed at the beginning of each semester in an educational setting.

2.0 System Installation

Proper installation is critical to safe and reliable operation and should be performed by a licensed electrician. A lab specific schematic diagram will be provided with a system purchase.

2.1 Wiring Concept Separate modules can be placed in series to form a complete operational system. The modules can be placed in any order to form a complete system, but they must be wired in “series” and **must be terminated with a “start” and “end” termination.**

Example:

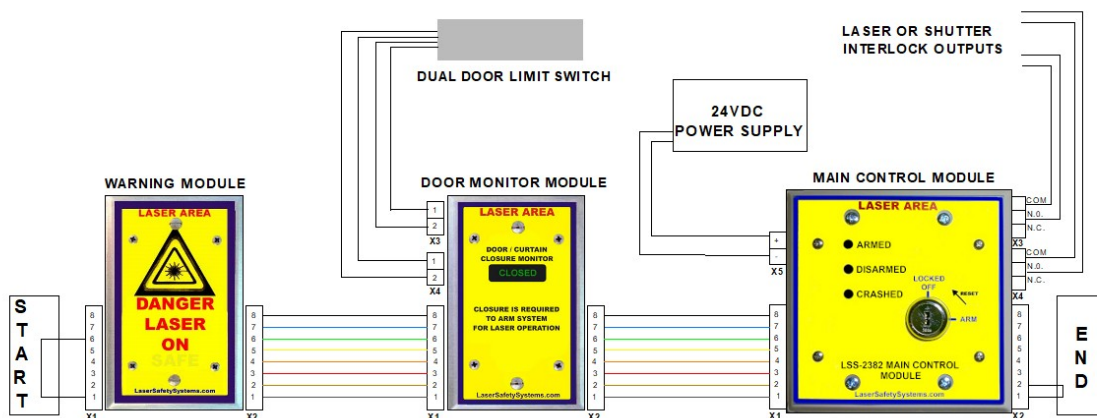

The main cable used to wire all modules together is 20 AWG, 8 conductor, stranded wire type with eight distinct colors. Our standard wiring for terminal strips X1 and X2 follows:

- 8-WHITE
- 7-BLUE
- 6-GREEN,
- 5-YELLOW
- 4-ORANGE
- 3-RED
- 2-BROWN
- 1-BLACK

2.2 Start / End Nodes

Provided with every system purchase, the start and end nodes are simply wire jumpers on the X1 and X2 terminals that loop back control power through the interlock cable. We could have simply instructed the installer to jumper one end 6 to 1 and the other end 1 to 2, but there is less confusion when the jumpers are pre-made.

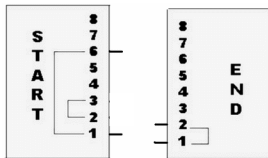

2.3 System Power Requirements

Power is supplied to the interlock system by our UL24V power supply, a 24 VDC UL/CE rated power supply with 1 Amp capacity. The RED terminated wire is +24V and the other wire is a common return. The client also has the choice of providing their own power, as long as it meets the 24VDC and minimum 1 amp capacity.



Power is introduced via the surface mounted box containing the Main Control Module (LSS-2382). The input is fused with a PTC fuse on the printed circuit board that will automatically reset when the fault condition has been corrected.

A specialized cord grip is provided with the LSS-2382 and LSS-2384 to accommodate I/O wiring. The soft rubber cable gland is specifically designed for this purpose. **DO NOT USE A METAL ROMEX CLAMP** at this location.



2.4 Conduit and Box Selection



Various interconnect methods can be used. The conduit may be rigid or flexible metallic or non-metallic type. Some clients choose to install without conduit by using the low voltage in-wall wiring solutions. The mounting boxes may be regular in-wall, low voltage drop-in boxes, or surface mounted boxes.

If you are providing boxes, they must meet the following minimum interior dimensional clearances:

Single Gang: Opening width of 48.5mm, height of 71mm, depth of 38mm
1.91" W, 2.8" H, 1.5" D

Dual Gang*: Opening width of 88.5mm, height of 71mm, depth of 38mm
3.5" W, 2.8"H, 1.5" D

*LSS-2382 and LSS-2388 modules are dual gang

Many options for component mounting are possible. If the laser table is centered in a room, you may wish to use a floor to ceiling conduit box as shown in the left image below which uses Wiremold® steel conduit box and component mounting boxes.

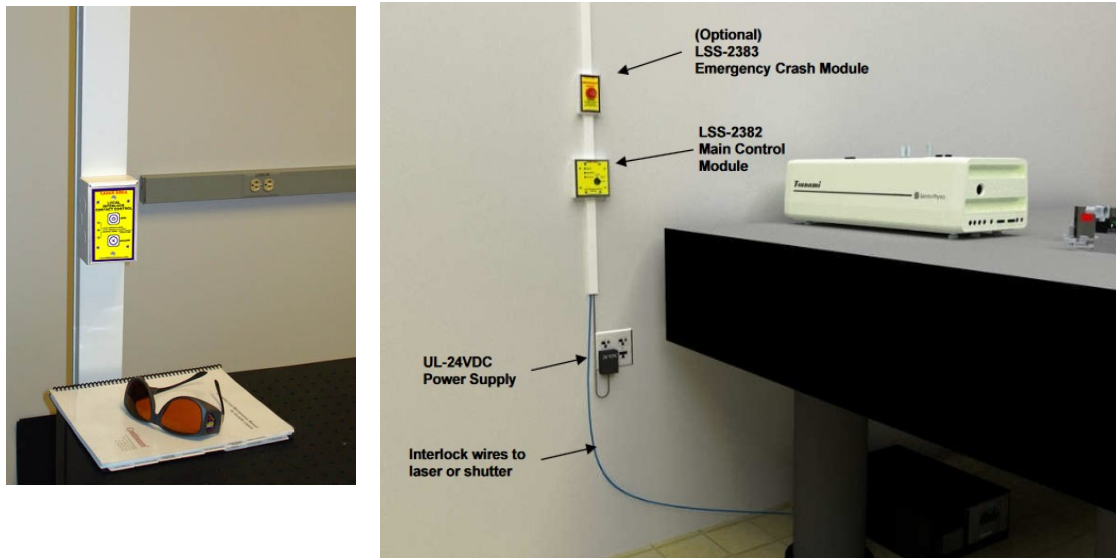

The image on the right shows a recommended layout if the laser table is near the wall. This installation uses the Hellermann-Tyton brand of low-voltage surface track and mounting boxes carried by Laser Safety Systems. An adhesive backing on the track and boxes allows installation without drilling or screwing to the wall.

3.0 Interlock Module Descriptions

3.01 LSS-2380 Laser Warning Module

The Laser Warning Module provides a clear visual indication of the present interlock state. It is microprocessor controlled to enhance the ability to communicate information to laser workers.



The module can indicate three different interlock states:

1. Normal Safe State (ready to arm) – Green “LASER SAFE” text is displayed.
2. Crashed Safe State – Green “LASER SAFE” text flashes on and off once per second.
3. Laser ON – A high power LED illuminates the Yellow triangle that displays the international laser warning symbol and red text displays “DANGER LASER ON” or “LASER ON”

Operation:

Operation is automated. The module senses the condition of the room interlock and displays the appropriate message.

Strobe effect: The triangle shaped bezel normally illuminates solid yellow. If the client wants it to strobe, X1 or X2 pin 2 is shorted to pin 3 anywhere in the system.

No “DANGER” text: Some clients have asked for the ability to turn off the text that says “DANGER”, when the interlock is armed. This is accomplished with a switch on the back of the printed circuit board. When the switch is on, the wording displayed when the interlock is armed will simply say “LASER ON” in a bright red.

3.02 LSS-2381 Interlock Control Module



This module can be used in addition to the LSS2382 Main Control Module to arm, disarm, or reset the laser interlock system in a location that is remote to the Main Control Module. The Main Control Module key must be in the ARM position to allow this module to arm or reset the system. One or more interlock control modules can be placed anywhere within a single laser area. The “DISARM” button will always take precedence over a request to arm the system, including the “ARM” position of the LSS2382 Main Control Module.

The “ARM” and “DISARM” momentary pushbutton switches are accompanied by LED’s which indicate the state of the system.

Operation:

No LED's lit- The system has lost power

Room Crashed LED lit – One or more modules is keeping the system in a crashed state. Check that all E-Stop buttons are released. The system cannot arm from this state

Room Disarmed LED lit- The system is ready to arm. Press “ARM” button to arm the system.

Room Armed LED lit- The system is armed.



Note: If the LSS2382 Main Control Module key is in the “LOCKED OFF” position, this module will see it as a room disarmed / ready to arm condition, but if you attempt to arm the LSS2381 module, it will be immediately crashed because the interlock is locked out.

Note: The LSS-2382 did not exist before December 2023. All systems shipped prior to this date used the LSS-2381 module as the main arming module for the room, and power was introduced to the system through a LSS-2384 Local Interlock Module.

3.03 LSS-2382 Main Control Module



As the name implies, the Main Control Module is the primary base module that controls whether the system is armed or disarmed.

The module:

- Accepts input of system 24VDC power and distributes this power along the 8-conductor main interlock cable to all other installed modules.
- Provides two Form C dry relay contacts to interlock a clients laser or shutter controller.
- Displays the room interlock status.
- Is provided with 2 Class 3 high-security “sidewinder” keys. Laser Safety Systems tracks key assignments so clients will receive uniquely keyed modules for clients with multiple labs, unless a common key is requested.
- Up to 5000 unique combinations are possible with this key and tumbler type.

Main Control Module operation:

No LED's lit- The system has lost power

CRASHED LED lit – One or more modules is keeping the system in a crashed state or the “start or end” jumpers that terminate the ends of the interlock cable run are not in place. Check that any installed LSS-2383 E-Stop buttons are released and doors or curtains monitored with the LSS-2387 Door/Curtain monitor are showing “CLOSED” on the front of the module . The system cannot arm from this state

DISARMED LED lit- The system is ready to arm. Rotate the key to the “ARM” position to arm the system. Note: If the key is already in the “ARM” position and the DISARMED LED is lit, some other module has tripped the interlock. Rotate the key briefly to the “LOCKED OFF” position to reset the module and then rotate clockwise to arm the system.

Armed LED lit- The system is armed.

The key can be removed in either position. The key should be removed and stored in a safe location when the system is not in use. You are provided with two keys at time of purchase. **DO NOT LOSE YOUR KEYS!**

Main Control Module mounting:

The Main Control Module is usually mounted near a laser table where it is convenient for the laser operator to arm and disarm the room and arm the local laser. The module must also be located within 4 feet of a power outlet.

Laser interface connection choices you need to make:

ANSI Z136.1 dictates that the energy produced by the laser or laser system shall be tripped to < MPE when commanded by the interlock system. This means that the interlock system does not need to actually trip the laser power off, but may instead simply trip a shutter that has been installed in such a manner as to render the output beam safe. The choice to interlock the laser **or** a shutter placed immediately on the output of the laser should be made by consensus of the laser system supervisor and laser safety officer.

Every commercial Class 3b or Class 4 laser or commercial safety shutter controller will have an interlock connector on its power supply. This connector usually has a small wire shorting between two terminals. This short is removed and the terminals are wired to the X3 or X4 relay contacts. Our 8 conductor cable can be used for this connection by simply using a single pair from the cable. The end user is usually responsible for connecting a laser or shutter to this interlock relay.

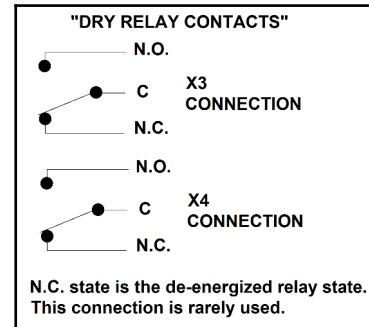

3.04 LSS-2383 Emergency Crash Module



The EMERGENCY CRASH MODULE is a safety device specified in ANSI Z136.1-2014 section 4.3.10.2.1. It should be placed in a location quickly accessible to the laser workers and it is intended to be used for emergency deactivation of the laser or laser shutter to reduce the output levels at or below the applicable MPE. The ANSI standard often shows this module placed at an entryway so first responders can quickly disarm the system during an emergency.

The module has control priority over all interlock controls. Multiple modules may exist on the system.

Operation: Push the mushroom head to crash the interlock system. The system will drop to a “CRASHED” state. If a laser power supply is interlocked to the system, the laser output will be terminated. If shutter controls are wired to the system, the shutter will close. Twist the mushroom head 1/8 turn clockwise to reset the switch to its normal “ready” state. The red LED backlight is illuminated whenever the interlock system is armed.

3.05 LSS-2384 Laser / Shutter Interface Module



The Laser / Shutter Interface Module is used when the client has more lasers or shutters than the LSS-2382 Main Control Module can accommodate. This module contains two dry safety relay contacts for interface to lasers and/or shutters.

When the room interlock is set, this local relay can be armed and disarmed via the front panel buttons. If the room interlock is disarmed or tripped off due to a safety function, all attached LSS2384 modules will also drop to the safe state.

Operation: When the room is armed, the “ROOM NOT ARMED” LED on the front of this module will turn off. The ARM and DISARM buttons will now cycle the internal safety relay when pressed. The LED’s on the front of this module will provide positive feedback of the present relay state.

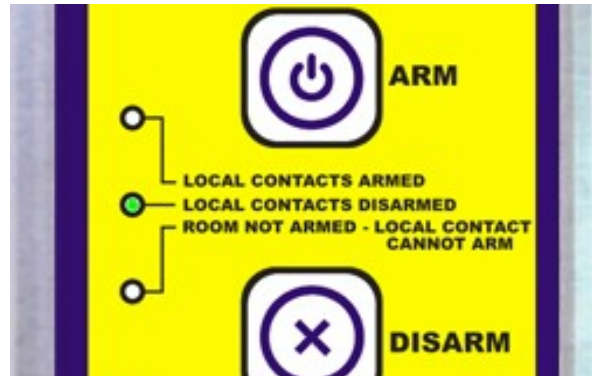

Note: If **automatic arming** of an individual 2384 module is desired, a switch is provided on the rear circuit board of this module. With this switch ON, the module will arm and disarm simultaneously with the room interlock.

Note: If your existing system does not contain a LSS-2382 Main Control Module, then 24vdc system power was introduced via the power input terminals on the LSS-2384 module, and a LSS-2381 Room Interlock Module was used to arm and disarm the room. Power is only introduced at one module in the system.

3.06 LSS-2387 Non-Defeatable Access Monitor

The non-defeatable access monitor module is usually installed on doors that are not used for access during laser operations. The dual magnetic limit switches monitor the door integrity. If the door is opened during laser operations, the interlock system will trip. The green text on the front of the module is illuminated when the door is closed to provide a visual indication of door closure. An open door or loss of power will show no text.

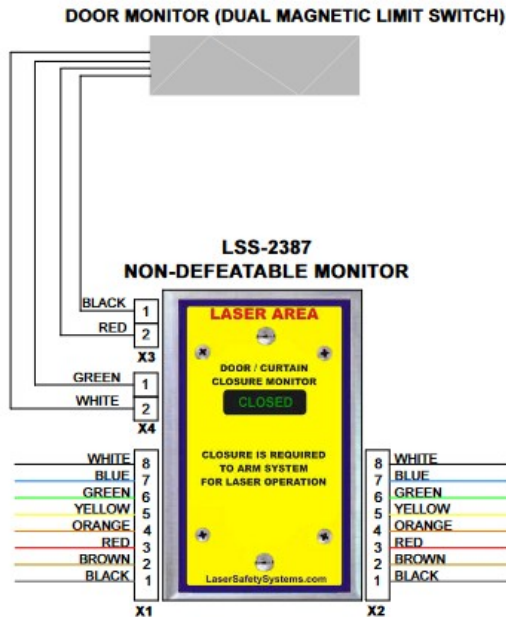

The dual contact limit switch is connected to X3 pins 1,2, and X4 pins 1,2 as shown above with the colors black, red, green and white respectively.

The door sensor is placed at the top of the door. The piece with the armored cable contains two independent magnetic reed switches and mounts to the door frame. The piece without the cable contains a magnet and mounts to the swinging door. A mounting bracket is provided to adjust the gap for this switch. The switches will be closed if the gap is less than ½ inch. The switches should be open when the door has opened the gap to about one inch.

3.07 LSS-2387B Non-Defeatable Access Monitor

Identical in operation to the LSS-2387, the LSS-2387B contains an additional relay that can be used to control auxiliary circuits of the clients choosing. The relay energizes when the room interlock is SET for laser operations.

The X5 connector is a 6 pin terminal strip for auxiliary functions. A DPDT relay is attached to this terminal strip providing dry relay contacts for user circuitry.

The contacts are rated for carry current of up to 8 Amps @ 250VAC

The auxiliary contact set can be used for any function desired by the client. Typical uses include activation of Bi-Lume lighting or deactivating card reader electric strike controls to prevent access through the specified door during laser operations.

The X5 connector is clearly labeled, showing deck 1&2 Common (C), Normally Open (N.O.), and Normally Closed (N.C.) contact designations.

3.08 LSS-2388 and LSS-2388EZ Defeatable Access Control Kits



The LSS-2388 is our all-in-one advanced defeatable access controller that connects via our interlock cable. The features and operation are too complex to cover in this manual, so there is a second manual devoted entirely to the LSS-2388 and another dedicated to the LSS-2388EZ. If you have purchased one of these kits, the manual will come with the kit. If you wish to review the manuals now, they are available on the “manuals” page of our web site. T

4.0 System Troubleshooting

If the system does not power up or perform as expected, there are several methods of troubleshooting available to locate the source of the problem. All modules are tested prior to shipment; therefore the most likely fault is a crossed wire or cable connection. Once the error is located and corrected, the system should operate normally because the modules are generally fault tolerant.

Step1: Make sure the system is powered with proper polarity and the crash switches are not depressed. (Rotate them 1/8 turn clockwise to release)

Step2:

- Check color code through all terminals. A single crossed color pair will prevent proper operation.
- Verify that all terminals are properly tightened on the stripped wire and not accidentally tightened on the un-stripped insulation.
- Verify the “Start” and “End” jumpers are in place at the beginning and end of the system wiring.
- A large system of modules can quickly be split in half to diagnose the location of the fault. Let’s take a look at the following example of a system of medium complexity:

Troubleshooting continued:

Step 3: It should be evident from Figure 1 and 2 that the upper half of the system is now active. Recall that the start and end jumpers are simply wires, so if you have cut it in half by disconnecting the lower portion, you only need to jumper line 1 to 2 to check the upper half.

Does the LSS-2382 arm the system now? If it does, then the fault was in the lower half and you would expand out by adding the main cable back to module and splitting it further down the line to locate the exact cause of the problem.

Step 4: If the fault remains in the upper half, you would further split the system by disconnecting items to the left of the LSS-2382 and jumping line 6 to 1 to simulate the “start” jumper.

By reducing system size and moving start and end jumpers, one can quickly locate the faulty module or wiring error. If you have reduced it down to the LSS-2382 alone, terminated with start and end jumpers and it still does not arm, then the LSS-2382 module itself is faulty and must be returned to Laser Safety Systems for repair or replacement.

Troubleshooting with a digital volt meter:

The figure below gives a schematic representation of the internal wiring of the laser interlock system main interlock cable. 24VDC enters the system at the LSS-2382 main control module (not shown) and is applied to the PIN 6 line (green). 24V common return is applied to the PIN 7 line (blue). Knowing this, you can go to ANY primary module in the system and you should measure 24VDC from PIN 6 to PIN 7 on the X1 or X2 terminal strips. If you do not measure 24VDC at the ends, you have a crossed wire somewhere in the system.

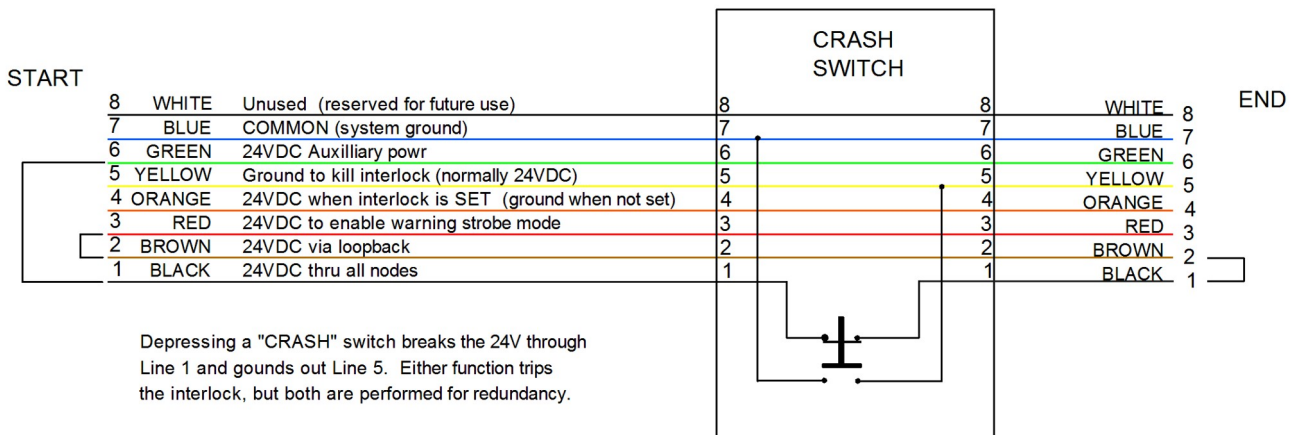

The START NODE transfers the +24VDC from PIN 6 to PIN1. There are several modules in the line that have the ability to break line 1 when activated. This is demonstrated by the crash switch shown above. If all systems are set for operation, the 24V will reach the END node where the voltage will be transferred to line 2 and supply power to card level circuitry.

Line 3 is a line that can float or it can be brought high with a jumper from line 2 to enable “strobe” mode on the LSS-2380 warning modules This jumper activates the strobe on all warnings when the interlock is set. If the 2 to 3 jumper is removed, all LSS-2380 modules will illuminate with a solid yellow instead of a strobe.

If you have performed these steps and located a faulty module, please contact Laser Safety Systems for a replacement. In the unlikely event the troubleshooting is not productive, contact Laser Safety Systems for additional advice.

Email: support@lasersafetysystems.com

Support Phone: (757)229-6109

5.0 Periodic Performance Test Procedure

The interlock system should be tested on an annual or semi-annual basis. We recommend educational facilities perform a test at the beginning of each semester.

The performance test will vary based on the components selected for the system. As a minimum, the following functions should be demonstrated.

1. Laser system should not be capable of producing light above the applicable MPE with the interlock system disarmed.
2. Any crash switch depressed in the system should drop the system to a safe state and prevent re-arming of the system.
3. Once pressed, the crash switches should hold the safe state and should require another separate action to reset the switch. (1/8 turn clockwise motion)
4. The system will not return to an armed state when a crash button is reset. Re-arming must be performed using the LSS2382 Main Control Module key switch, or LSS2381 arming button if system is equipped with the LSS2381 module.
5. The system should not be capable of arming if a monitored door is open. (LSS2388 system will briefly allow arming, but sound an alarm and quickly disarm the system if the door is held open)
6. The system should immediately drop to a safe state if armed and a closed door is opened without proper bypass processes.
7. Rapid egress from the room shall be possible at all times.
8. A means to access the room in an emergency should be possible. If this access method does not directly crash the interlock system, there should be a crash button installed at a location where it can be pressed without entering the nominal hazard zone.
9. Defeatable access systems must have a timeout and trip the interlock if the door is left open beyond the timeout period.
10. Installed warning devices should be checked for proper operation.

6.0 Module Cleaning Procedure

Faceplates shall only be cleaned with light pressure rubbing from a paper or cloth tissue soaked with a 50% solution of Isopropyl (Rubbing) Alcohol and water.

7.0 Warranty

Notwithstanding any provision to the contrary, Seller's sole and exclusive obligations to the Customer for any Product made by Seller and sold hereunder are to repair returned Product or provide a replacement Product, at Seller's sole option, for any Product which has been returned to Seller under the RMA procedure (below) and which in the reasonable opinion of Seller is determined to be defective in workmanship, material or not in compliance with the mutually agreed written applicable specifications and has in fact failed under normal use on or before three (3) years from the date of original shipment of the Product. All third parties' Products sold by Seller carry only the original manufacturer's warranty applicable to Customer. Seller will only accept for repair, replacement or credit under warranty Products made by third parties if expressly authorized to do so by the relevant third party. Any Product repaired or replaced under warranty is only warranted for the period of time remaining in the original warranty for the Product. Seller reserves the right, at its sole option, to issue a credit note for any defective Product as an alternative to repair or replacement. The warranty provided herein shall extend to any Product which has proved defective and has failed through normal use, but excludes and does not cover any Product or parts thereof which has been accidentally damaged, disassembled, modified, misused, used in applications which exceed the Product specifications or ratings, neglected, improperly installed or otherwise abused or is used in hazardous activities. Customer must claim under the warranty in writing not later than thirty (30) days after the claimed defect is discovered. The Customer must make all claims under this warranty and no claim will be accepted from any third party.

8.0 Return Material Authorization Procedures

Seller will only accept Products returned under the Seller's Return Material Authorization process ("RMA"). Customer shall obtain a RMA number from Seller prior to returning any product.