

# LSS-2386B Installation and User Manual

Thank you for your purchase of the Laser Safety Systems 2386B Defeatable Access Control Kit.

Your kit contains the following components:

1-LSS-2386B Access Control Module

1-LSS-2386C "Push-Before-Exit" module

1-Dual contact magnetic sensor with 12" long stainless steel armored cable.

**NOTICE: The LSS-2386B Defeatable Access Control System does not secure the laser during electronic approved access. The facility must ensure that the level of radiation at the entry point does not exceed the safe ocular or skin MPE. Laser curtains are usually placed at the entryway to permit safe door opening.**

The LSS-2386B module is intended for installations using card or key readers connected to an electric strike as shown below:

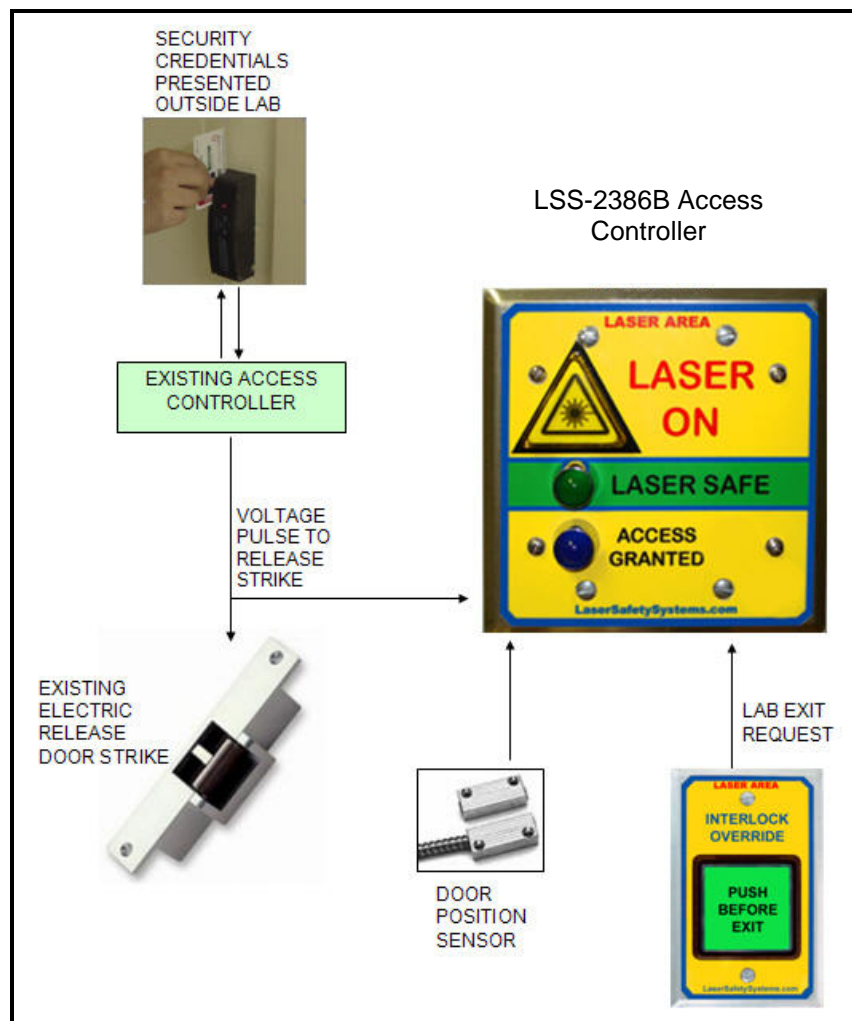

The normal entry process will automatically override the door position sensor to grant access to laser trained individuals during laser operation. The facility must ensure that the access controller is programmed to only give access to laser trained personnel. When this is not possible, some facilities have chosen to install two card readers, the first one for all personnel and a second for laser trained personnel. The auxiliary relay in the LSS-2386B is then configured to disable the first card reader during laser operation.

## LSS-2386B module wiring

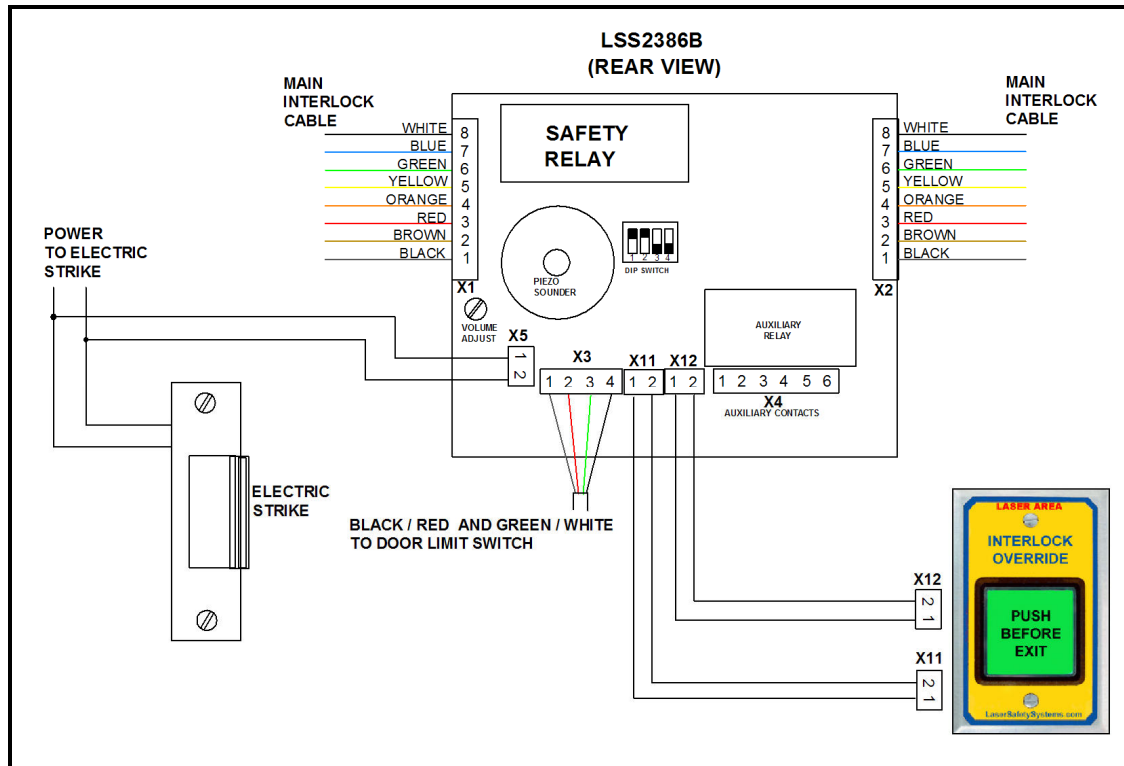

### Main Interlock Cable connections (X1 and X2)

The main interlock cable is wired through the X1 & X2 connectors as specified.

### Door Limit Switch input (X3)

The dual contact limit switch is connected to X3 pins 1,2,3,4 as shown above with the colors black, red, green and white respectively.

The door sensor is placed at the top of the door. The portion with the armored cable contains two independent magnetic reed switches. This portion mounts to the door frame. The portion without the cable contains a magnet. This mounts to the swinging door. A mounting bracket is provided to adjust the gap for this switch. The switches will be closed if the gap is less than ½ inch. The switches should be open when the door has opened the gap to about one inch.

### Auxiliary contact sets (X4)

The printed circuit board provides a 6 pin terminal strip for auxiliary functions. A DPDT relay is attached to this terminal strip. The relay energizes when the room interlock is SET.

The contacts are rated for carry current of up to 8 Amps @ 250VAC

The auxiliary contact pinout is:

1. common (deck 1)
2. normally open (deck 1) (closes when interlock system is armed)
3. normally closed (deck 1)
4. common (deck 2)
5. normally open (deck 2) (closes when interlock system is armed)
6. normally closed (deck 2)

The auxiliary contact set can be used for any function desired by the client. Typical uses include activation of Bi-Lume lighting and switching card reader systems to limit access during laser operations.

## Electric Strike input (X5)

It is assumed that the electric strike used is “powered to unlock”.

Pins 1 and 2 of X5 receive a signal pulse from the electric strike to activate an interlock override condition. The input is not polarity sensitive. It will trigger with any momentary input of 12 to 24 volts (DC or AC). The input is electrically isolated from all interlock circuitry through an optical isolator.

## Push-Before-Exit switch input (X11)

Terminals 1&2 of X11 expect to see a normally closed switch circuit as provided by the included exit switch. The client may wire a motion detector or REX crash bar switch to this terminal set instead as long as it is wired as a normally closed circuit.

## Push-Before-Exit Backlight LED driver (X12)

X12 terminal 1 provides 24VDC when the interlock system is armed to illuminate the exit switch. Terminal 2 is a common return. This terminal set can also be used to provide power to a motion detector as long as it consumes less than 75mA.

## Dip Switch Settings

The DIP switch is used to set the door timer and strobe mode. Switch 1, 2 and 3 control timing while switch 4 selects strobe mode. The minimum time setting is 10 seconds. The timing switches may be used in combination for a total of 45 second access time.

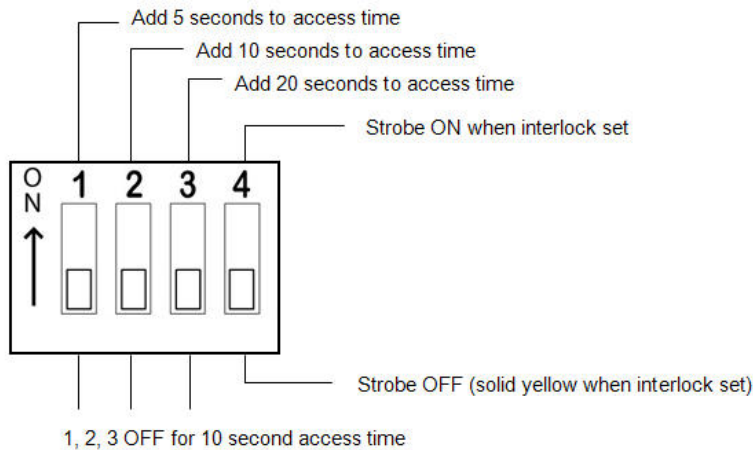

## Volume Control

A small potentiometer is located immediately below the X1 connector to adjust module tone volume to suit the environment.

## LSS-2386B Operation

Interlock system safe is designated by a solid green LED.

Interlock system crashed is designated by a flashing green LED.

Interlock system armed is designated by a solid or flashing yellow indicator.

The module provides audible indication of each change of state.

### Features during “SAFE” mode:

There are several features designed into the system that are evident during safe mode. Each time the door is opened, an audible entry tone is generated. This tone is provided as a self check of the interlock system. It confirms that the microprocessor and dual magnetic limit switches are working properly. It is worth noting that the safety relay within the module is held in the energized state by a microprocessor charge-pump safety circuit. In the unlikely event of a microprocessor failure, the relay would drop the system to a safe mode.

### **Features during “LASER ON” mode:**

To exit the room with lasers operating: Push the “Push-Before-Exit” button. You will hear an “exit now” tone and see the blue access granted LED. If the client has installed a motion detector at the exit, the system will automatically initiate an override when the exit is approached.

To enter the room with lasers operating: Swipe your access card and you will hear the “user coming in” tone produced by the interior module. Open the door and enter. The door interlock will be bypassed for the time period programmed on the dip switch.

Holding the door open beyond access time: When the bypass timer is initiated, an audible count down tone is produced once a second for the time setting designated by the DIP switch. If the door is held open beyond this time, a loud warning tone is produced for three seconds. If the door is closed during this warning period, the interlock will remain armed. If the door is held open beyond this warning, the interlock system will trip to “SAFE” mode.

Unauthorized entry: If a key is used for entry or the door is opened by force, the interlock system will immediately trip off.

### **Intelligent Access Timing:**

The dip switch setting determines the maximum time the door can be held open, but there are several intelligent features built in to the controller.

1. If an override is initiated but the door is not opened within 5 seconds, the override condition is cancelled. A short cancel tone is produced to convey the condition to the user.
2. If an override is initiated and the door has been opened, the time set on the dip switch is counted. If the “Push-to-Exit” switch is depressed at any time during this access period, the timer is reset. This allows personnel to hold the door open for extended periods if needed to move a large object through the doorway.
3. When the door is closed after an access, the controller senses the closure and cancels the override condition within 2 seconds of closure. This allows the system to be ready for another entry or exit request without waiting for the normal timer to expire.